

General Safety Information

WARNING – To avoid serious injuries:

- Improper use of your bicycle's brake system may result in a loss of control or an accident, which could lead to a severe injury. Because each bicycle may handle differently, be sure to learn the proper braking technique (including brake lever pressure and bicycle control characteristics) for your bicycle. Consult your bicycle dealer and the bicycle's owners manual, and practice your riding and braking technique.
- Brakes designed for use as rear brakes should not be used as front brakes.
- Obtain and read the service instructions carefully prior to installing the parts.** Loose, worn, or damaged parts may cause serious injury to the rider. We strongly recommend only using genuine Shimano replacement parts.
- Be careful not to allow any oil or grease to get onto the brake shoes. If any oil or grease do get on the shoes, you should replace the shoes, otherwise the brakes may not work correctly.
- Check the brake cable for rust and fraying, and replace the cable immediately if any such problems are found. If this is not done, the brakes may not work correctly.
- Always make sure that the front and rear brakes are working correctly before you ride the bicycle.
- The required braking distance will be longer during wet weather. Reduce your speed and apply the brakes early and gently.
- If the road surface is wet, the tires will skid more easily. If the tires skid, you may fall off the bicycle. To avoid this, reduce your speed and apply the brakes early and gently.
- Read these Technical Service Instructions carefully, and keep them in a safe place for later reference.

CAUTION – To avoid serious injuries:

The power modulator is a device that makes it easier to control braking by increasing the cable stroke at the brake lever within a certain constant range of braking force. If the effective operating range of the power modulator will be exceeded, the lever stroke and the brake will operate as a normal V-BRAKE brake (sensitive and powerful). In that case, the brakes may operate more powerfully than intended and may cause the wheel to lock up. Therefore it is essential that you fully understand and test the performance of the power modulator before use. **The power modulator is not equipped with a function to prevent the wheel from locking up.**

Braking Performance Comparison

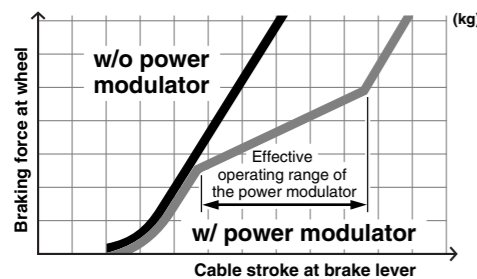

Shimano BR-M590 Safety Information

WARNING – To avoid serious injuries:

- Use the BR-M590 V-BRAKE brake with V-BRAKE brake-compatible brake levers such as the ST-M590/BL-M590 brake levers.
 - If using BR-M590 V-BRAKE brakes in combination with BL-M591/BL-M771 (3-finger) brake levers, or in combination with ST-M405/ST-M360 (4-finger) brake levers with mode switching which are compatible with V-BRAKE brakes with power modulator or with cantilever brakes or roller brakes, be sure to use the SM-PM70 power modulator with the V-BRAKE brakes. If the power modulator is not used, it may cause excessive braking force to be applied when the brake lever is operated, or result in an uneven cable stroke which can cause braking force to be insufficient, which in turn could result in dangerous accidents.
 - The ST-M405/ST-M360 (4-finger) brake levers are equipped with a mode switching mechanism to make them compatible with V-BRAKE brakes with power modulator, cantilever brakes and roller brakes.
- If the incorrect mode is selected it may cause either excessive or insufficient braking force to occur, which could result in dangerous accidents. Be sure to select the mode in accordance with the instructions given in the table below.**

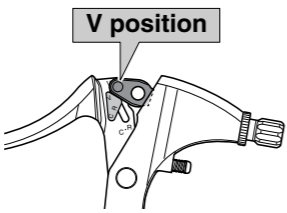
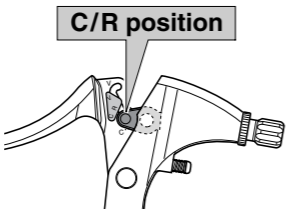
Mode position	Applicable brake
 <p>V position</p> <p>The V indicates the mode position for compatibility with V-BRAKE brakes with power modulator.</p>	<ul style="list-style-type: none"> V-BRAKE brakes (BR-M590) with SM-PM70 power modulator attached
 <p>C/R position</p> <p>The C indicates the mode position for compatibility with cantilever brakes.</p> <p>The R indicates the mode position for compatibility with roller brakes.</p>	<ul style="list-style-type: none"> Cantilever brakes Roller brakes

NOTE:

- The optimum efficiency of the Multi-Condition Brake System can be realized by using the brakes and brake levers in the recommended set.
- If the brake shoes have worn down until the grooves are no longer visible, they should be replaced.
- Parts are not guaranteed against natural wear or deterioration resulting from normal use.
- For maximum performance we highly recommend Shimano lubricants and maintenance products.
- For any questions regarding methods of handling or maintenance, please contact the place of purchase.

Multi-Condition Brake System

SI-8G50A-001

Technical Service Instructions

Multi-Condition Brake System

By providing superior wet weather braking performance (control and modulation), braking performance will not vary in a multitude of conditions when using this brake system.

In order to realize the best performance, we recommend that the following combination be used.

Series	DEORE	
Brake lever	BL-M590/ ST-M590	BL-M591
V-BRAKE brake	BR-M590	BR-M590 with SM-PM70
Brake cable		

Installation of the brake lever

Use a 4 mm Allen key to install the brake lever.

Use a handlebar grip with a maximum outer diameter of 32 mm.

Tightening torque:
6 – 8 N·m {52 – 69 in. lbs.}

In the case of carbon handlebars, it may be necessary to lower the tightening torque in order to prevent damage to the handlebar. Please consult the bicycle or handlebar manufacturer regarding the appropriate level of tightening torque for carbon handlebars.

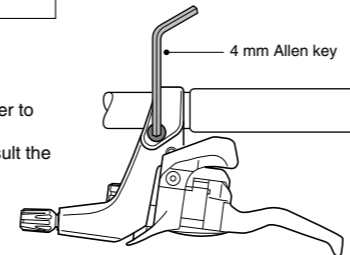

Installation of the V-BRAKE brake

- Insert the stopper pin of the brake body into the center spring hole in the frame mounting boss, and then secure the brake body to the frame with the link fixing bolt.

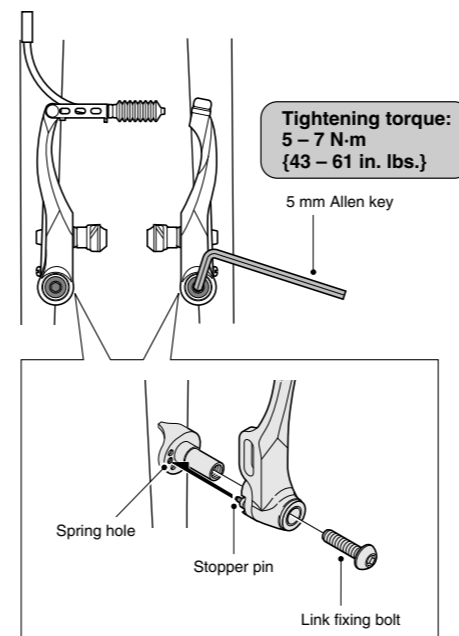

- While holding the shoe against the rim, adjust the amount of shoe protrusion by changing over the washer B (thick or thin) so that dimension A is kept at 32 mm or more.

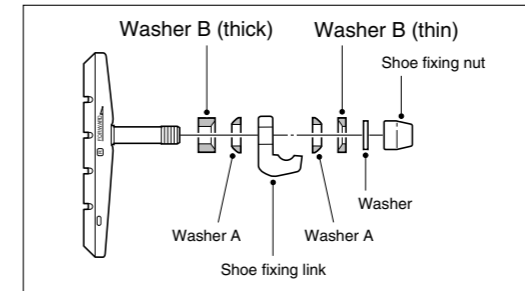
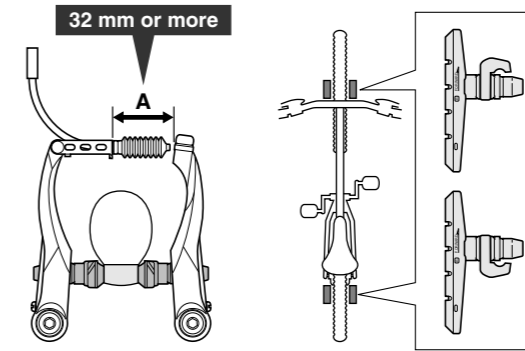

- While holding the shoe against the rim, tighten the shoe fixing nut.

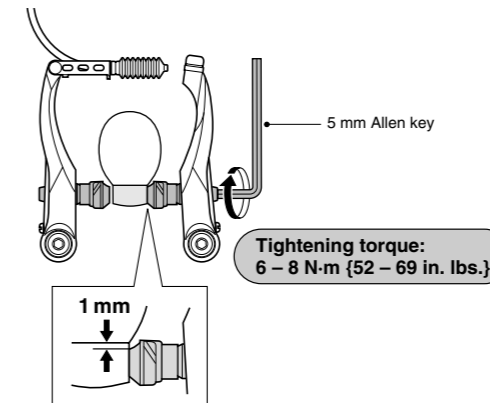

- Pass the inner cable through the inner cable lead, and after setting so that the total of the clearances between the left and right shoes and the rim is 2 mm, tighten the cable fixing bolt.

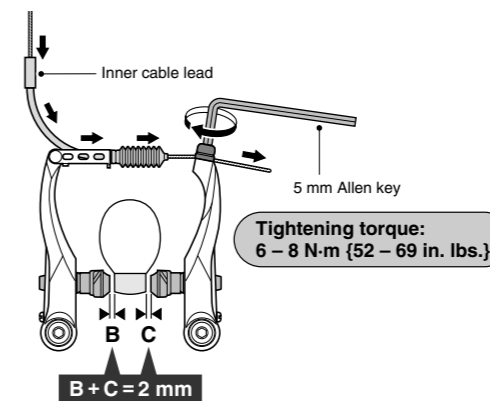

- Adjust the balance with the spring tension adjustment screws.

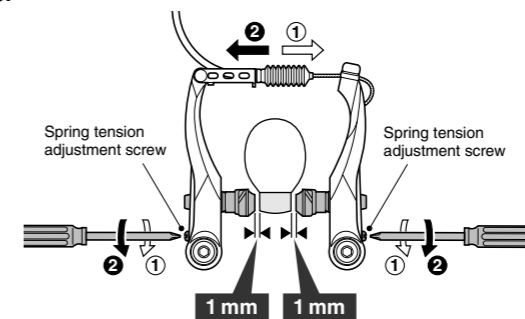

- Depress the brake lever about 10 times as far as the grip and check that everything is operating correctly and that the shoe clearance is correct before using the brakes.

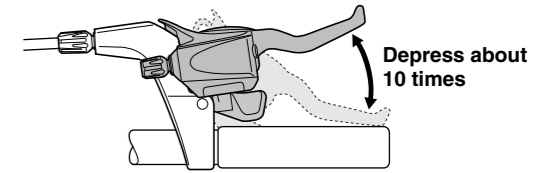

Replacement of the cartridge shoe

- Remove the shoe fixing pin, and then slide the shoe along the groove to remove it from the shoe holder.

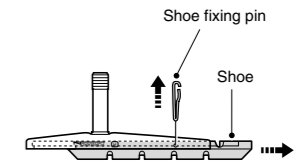

- There are two different types of shoe and shoe holder to be used in the left and right positions respectively. Slide the new shoes into the grooves on the shoe holders while taking note of the correct directions and pin hole positions.

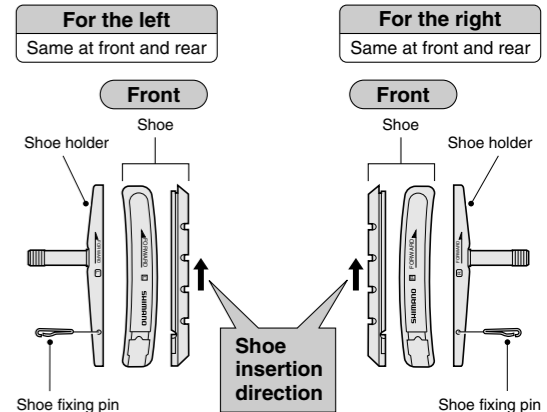

- Insertion of shoe fixing pin is very critical to keep shoe properly fixed in place.

Please note: Specifications are subject to change for improvement without notice. (English)

SHIMANO

SHIMANO AMERICAN CORPORATION
One Holland, Irvine, California 92618, U.S.A. Phone: +1-949-951-5003

SHIMANO EUROPE B.V.
Industrieweg 24, 8071 CT Nunspeet, The Netherlands Phone: +31-341-272222

SHIMANO INC.
3-77 Oimatsu-cho, Sakai-ku, Sakai, Osaka 590-8577, Japan